



AD8186/AD8187 Evaluation Boards

EVAL-AD8186EB/EVAL-AD8187EB

BOARD DESCRIPTION

An evaluation board has been designed and is offered for running the AD8186/AD8187 on a single supply. The inputs and outputs are ac-coupled and terminated with 75 Ω resistors. For the AD8187, a potentiometer is provided to allow setting V_{REF} at any value between V_{CC} and ground.

The logic control signals can be statically set by adding or removing a jumper. If it is required to drive the logic pins with a fast signal, an SMA connector can be used to deliver the signal; a place for a termination resistor is provided.

ORDERING GUIDE

Model	Package Description
AD8186-EVAL	Evaluation Board
AD8187-EVAL	Evaluation Board

CAUTION

ESD (electrostatic discharge) sensitive device. Electrostatic charges as high as 4000 V readily accumulate on the human body and test equipment and can discharge without detection. Although the EVAL-AD8186EB/EVAL-AD8187EB feature proprietary ESD protection circuitry, permanent damage may occur on devices subjected to high energy electrostatic discharges. Therefore, proper ESD precautions are recommended to avoid performance degradation or loss of functionality.



REV. 0

Information furnished by Analog Devices is believed to be accurate and reliable. However, no responsibility is assumed by Analog Devices for its use, nor for any infringements of patents or other rights of third parties that may result from its use. No license is granted by implication or otherwise under any patent or patent rights of Analog Devices. Trademarks and registered trademarks are the property of their respective companies.

One Technology Way, P.O. Box 9106, Norwood, MA 02062-9106, U.S.A.
Tel: 781/329-4700 www.analog.com
Fax: 781/326-8703 © 2003 Analog Devices, Inc. All rights reserved.

EVAL-AD8186EB/EVAL-AD8187EB

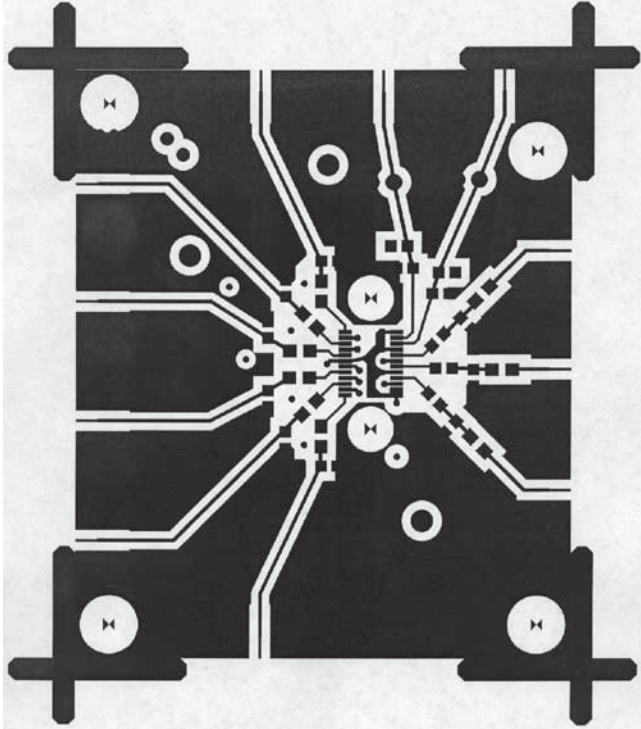

Figure 1. Component Side (Top)

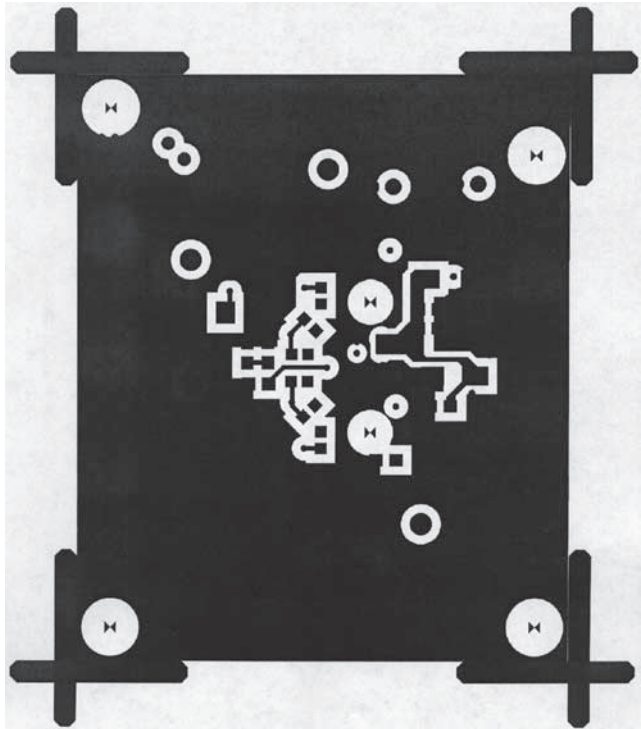

Figure 2. Component Side (Bottom)

EVAL-AD8186EB/EVAL-AD8187EB

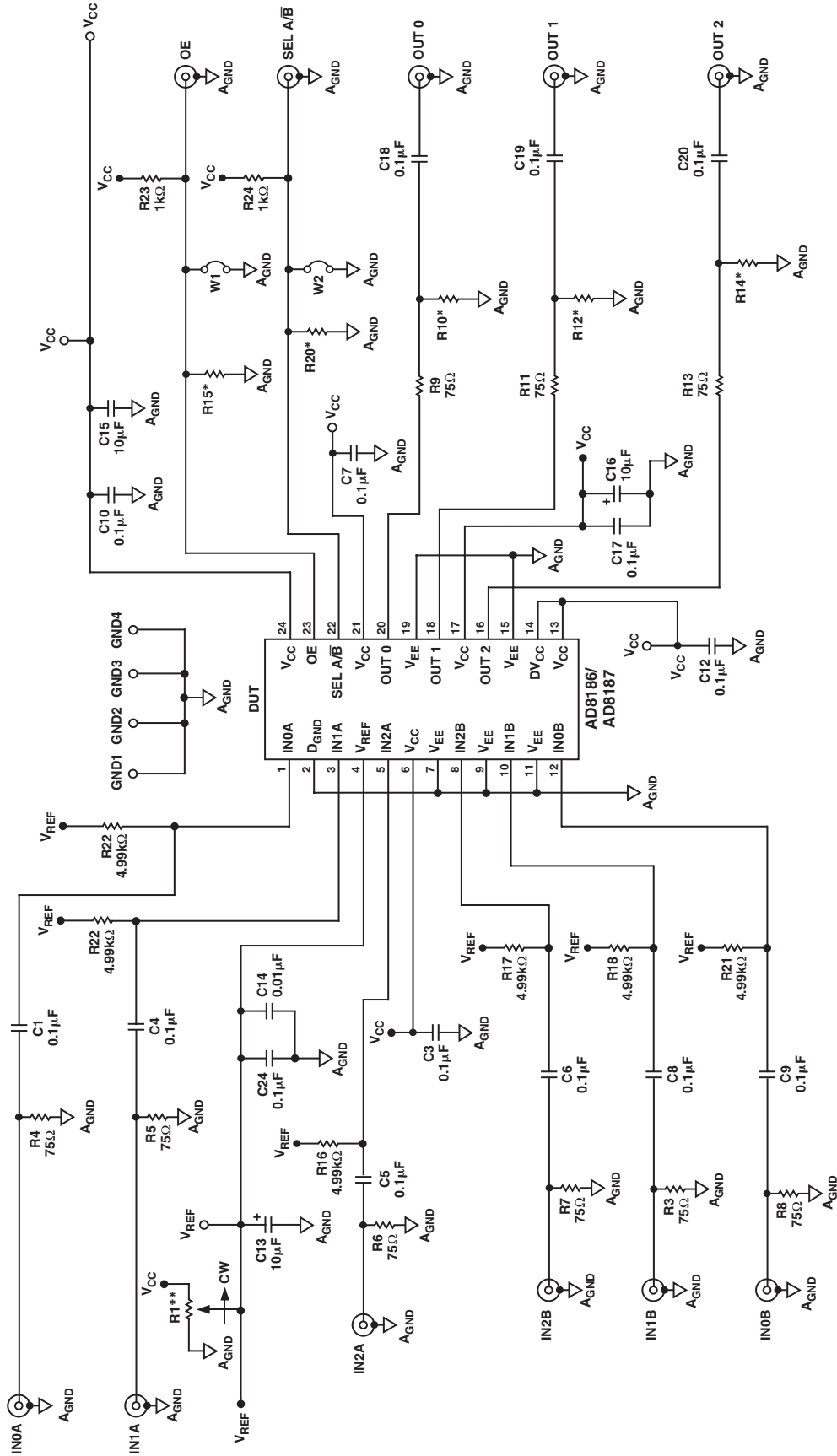

Figure 5. Single-Supply Evaluation Board

*R15, R20, R10, R12, AND R14 NOT INSTALLED ON EVALUATION BOARD FOR TEST PURPOSES.
 **R1 IS NOT USED FOR AD8186.